

Self-priming Pumps for Pure or Contaminated Fluids

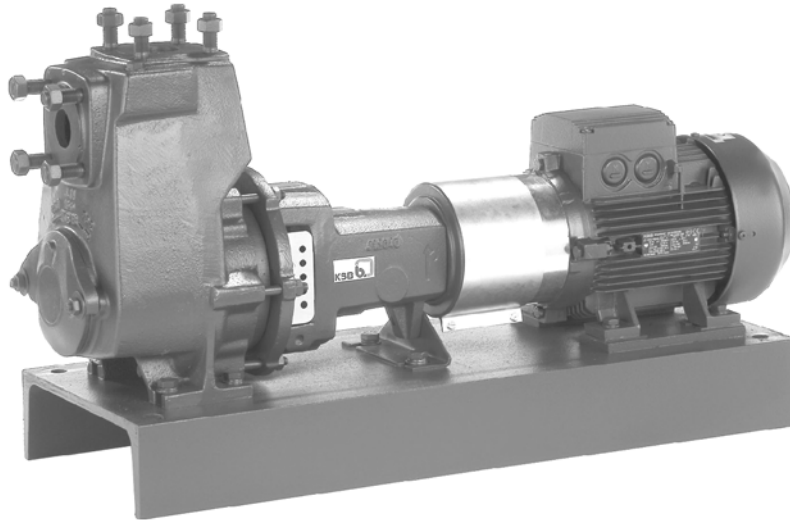

Fields of Application

- Water supply
- Fire-fighting systems
- Sprinkling
- Irrigation
- Drainage
- Air-conditioning systems
- Drinking water
- Industrial water
- Cooling water
- Swimming pool water
- Seawater
- Fire-fighting water
- Brackish water
- Condensate
- Brine
- Oils
- Cleaning agents

Operating Data

	50 Hz	60 Hz
Q	up to 180 m ³ /h (50 l/s)	up to 130 m ³ /h (36 l/s)
H	up to 85 m	up to 105 m
p ₂	up to 10 bar ¹⁾	up to 10 bar ¹⁾
H _{1geo}	up to 9 m	up to 9 m
t	-30 to +90 °C	-30 to +90 °C

1) see pressure limits, page 6

Design

Horizontal volute casing pumps, single-stage, with open multi-vane impeller, sizes 40-140 and above with bearing bracket, in back pull-out design.

Sizes 40-140 and above with replaceable shaft sleeve in the shaft seal area. Volute casing with integrally cast pump feet. Pump connections to DIN/EN or ASME.

Bearings

Deep-groove ball bearings, grease-lubricated

Shaft seal

Single- or double acting mechanical seal to EN 12 756.

Designation

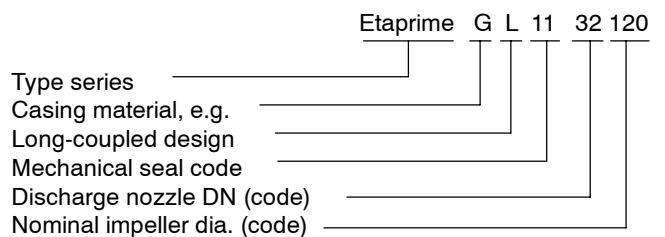

Accessories

Drive

Surface-cooled KSB-IEC three-phase squirrel cage motor
Winding 50 Hz: up to 2.2 kW 220-240 V/380-420 V
for 3 kW and above 380-420/660-725 V

Winding 60 Hz: 440-480 V

Design: IM B 3

Enclosure: IP 55

Thermal class: F with temperature sensors: 3 PTC thermistors

Operating mode: continuous operation S1 or

surface-cooled three-phase squirrel cage motor as described above, but West European brand to KSB's choice.

Coupling

Flexible coupling with/without spacer sleeve

Contact guard

Coupling guard as per EN 294.

Baseplate

Sectional steel for complete pump set (pump and motor), in torsion-resistant design

Certification

Certified quality management ISO 9001.

n = 1.450 1/min

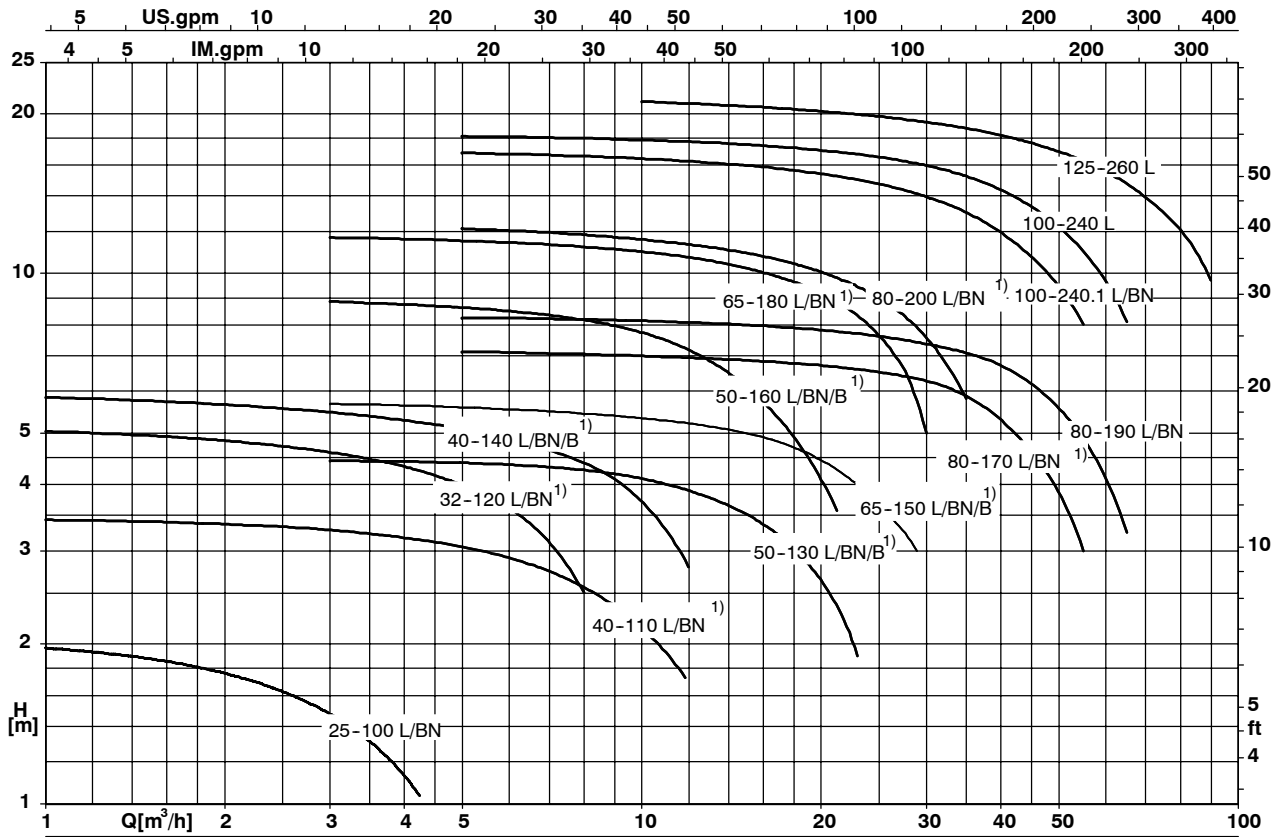

EP1450.01

- 1) lieferbar auch in Chrom-Nickel-Molybdänstahlguss
- 1) Suministrable también en Acero moldeado al Cr-Ni-Mo
- 1) also available in cast iron CrNiMo steel
- 1) Ook leverbaar in chroom-nikkel-molybdeenstaal
- 1) Egalement disponible en acier moulé au CrNiMo
- 1) Disponibile anche come fusione di acciaio al cromo-nichel-molibdeno

n = 2.900 1/min

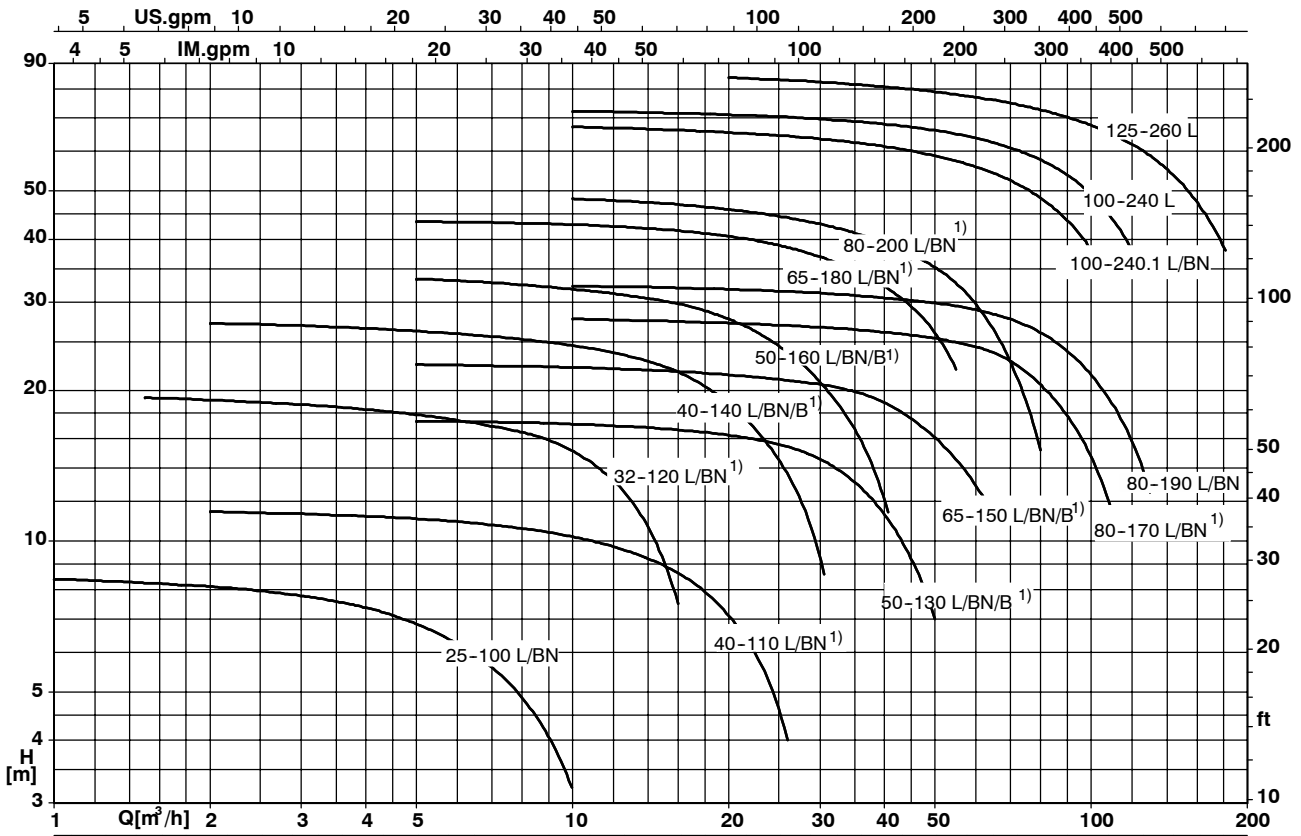

EP2900.01

- 1) lieferbar auch in Chrom-Nickel-Molybdänstahlguss
- 1) Suministrable también en Acero moldeado al Cr-Ni-Mo
- 1) also available in cast iron CrNiMo steel
- 1) Ook leverbaar in chroom-nikkel-molybdeenstaal
- 1) Egalement disponible en acier moulé au CrNiMo
- 1) Disponibile anche come fusione di acciaio al cromo-nichel-molibdeno

n = 1.750 1/min

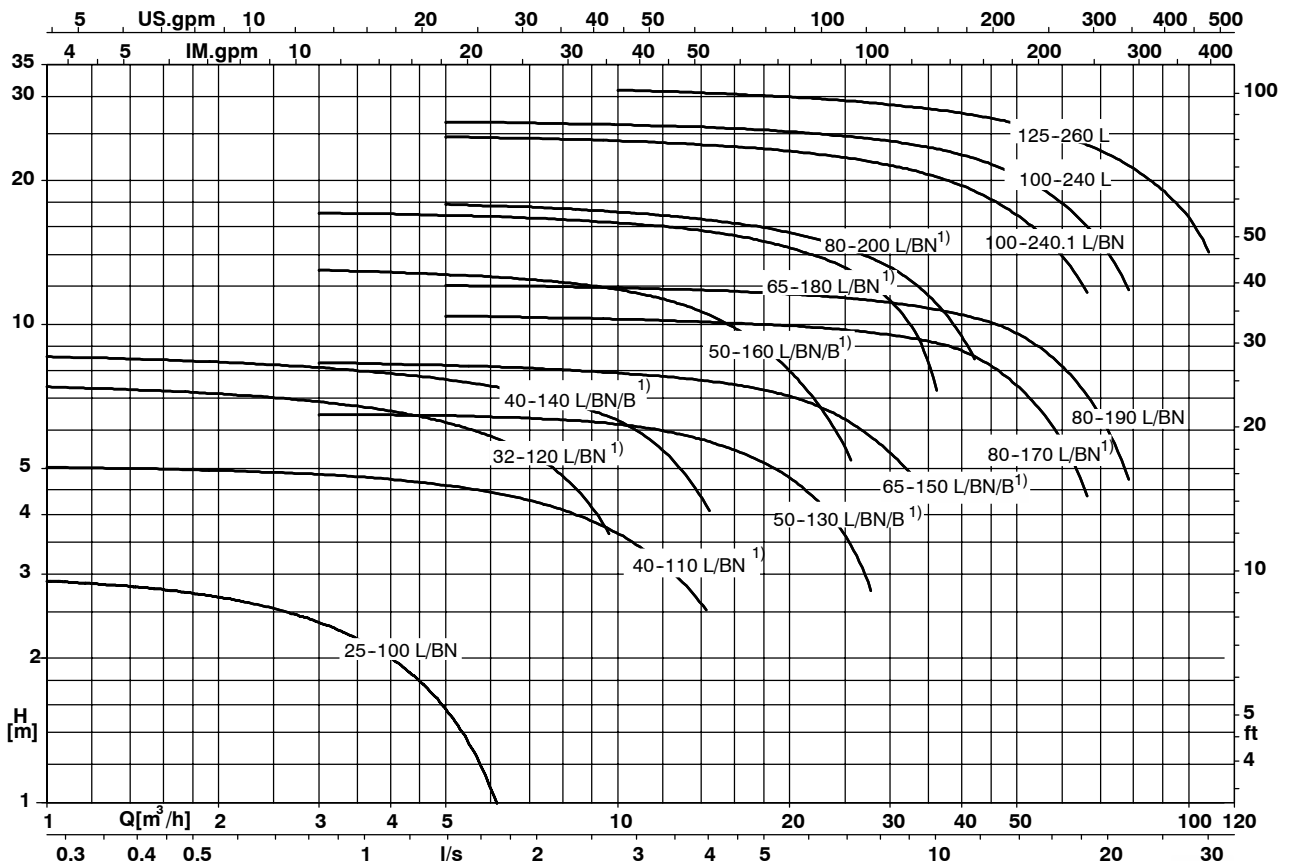

- 1) lieferbar auch in Chrom-Nickel-Molybdänstahlguss
- 1) also available in cast iron CrNiMo steel
- 1) Egalement disponible en acier moulé au CrNiMo
- 1) Suministrable también en Acero moldeado al Cr-Ni-Mo
- 1) Ook leverbaar in chroom-nikkel-molybdeenstaal
- 1) Disponibile anche come fusione di acciaio al cromo-nichel-molibdeno

EP1750.01

n = 3.500 1/min

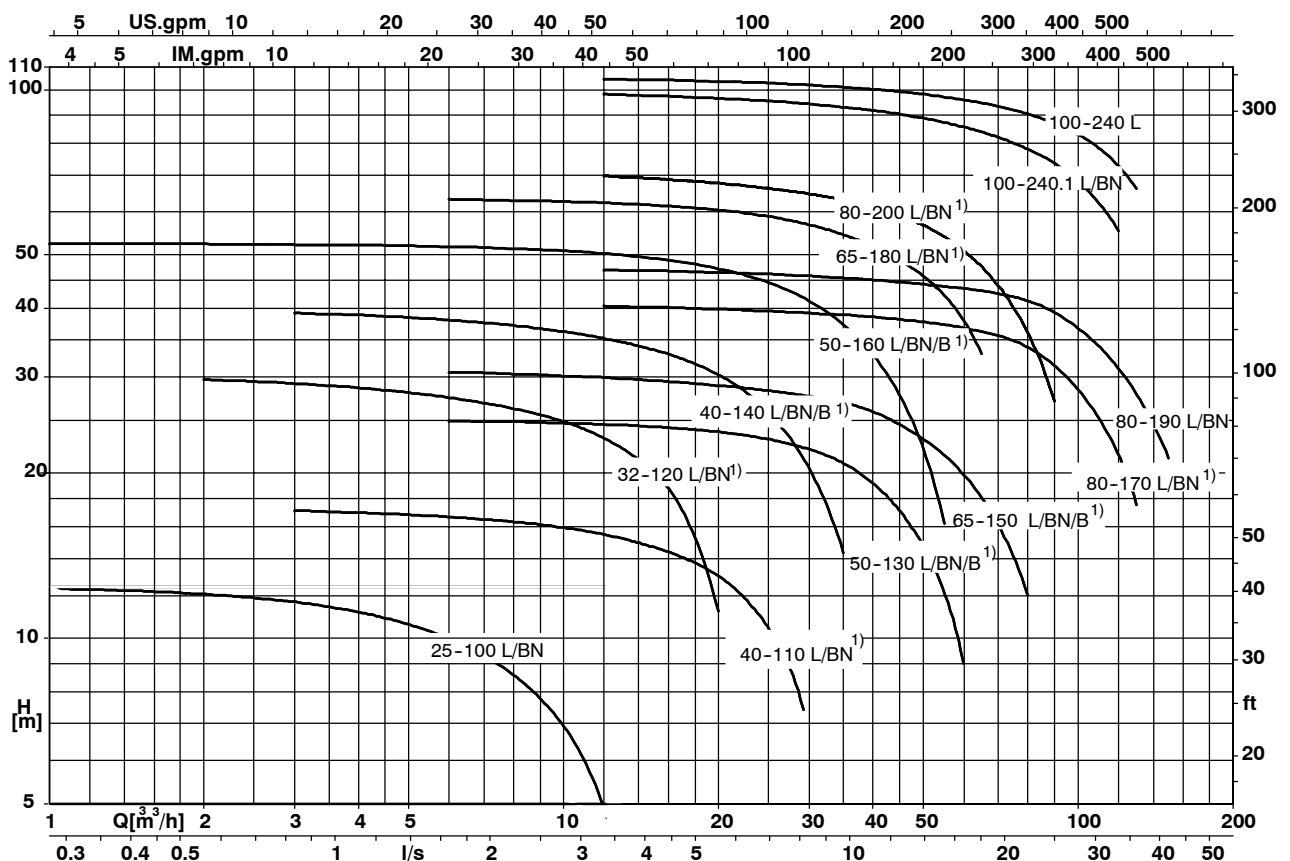

- 1) lieferbar auch in Chrom-Nickel-Molybdänstahlguss
- 1) also available in cast iron CrNiMo steel
- 1) Egalement disponible en acier moulé au CrNiMo
- 1) Suministrable también en Acero moldeado al Cr-Ni-Mo
- 1) Ook leverbaar in chroom-nikkel-molybdeenstaal
- 1) Disponibile anche come fusione di acciaio al cromo-nichel-molibdeno

EP3500.01

Product Advantages at a Glance

Self-priming after the pump casing has been filled with the fluid handled

Excellent suction behaviour, self-priming up to 9 m; no foot valve required

Pump unit is insensitive to the penetration of gas and air

Double-acting mechanical seal available for tough applications

High operating reliability due to sturdy deep-groove ball bearings

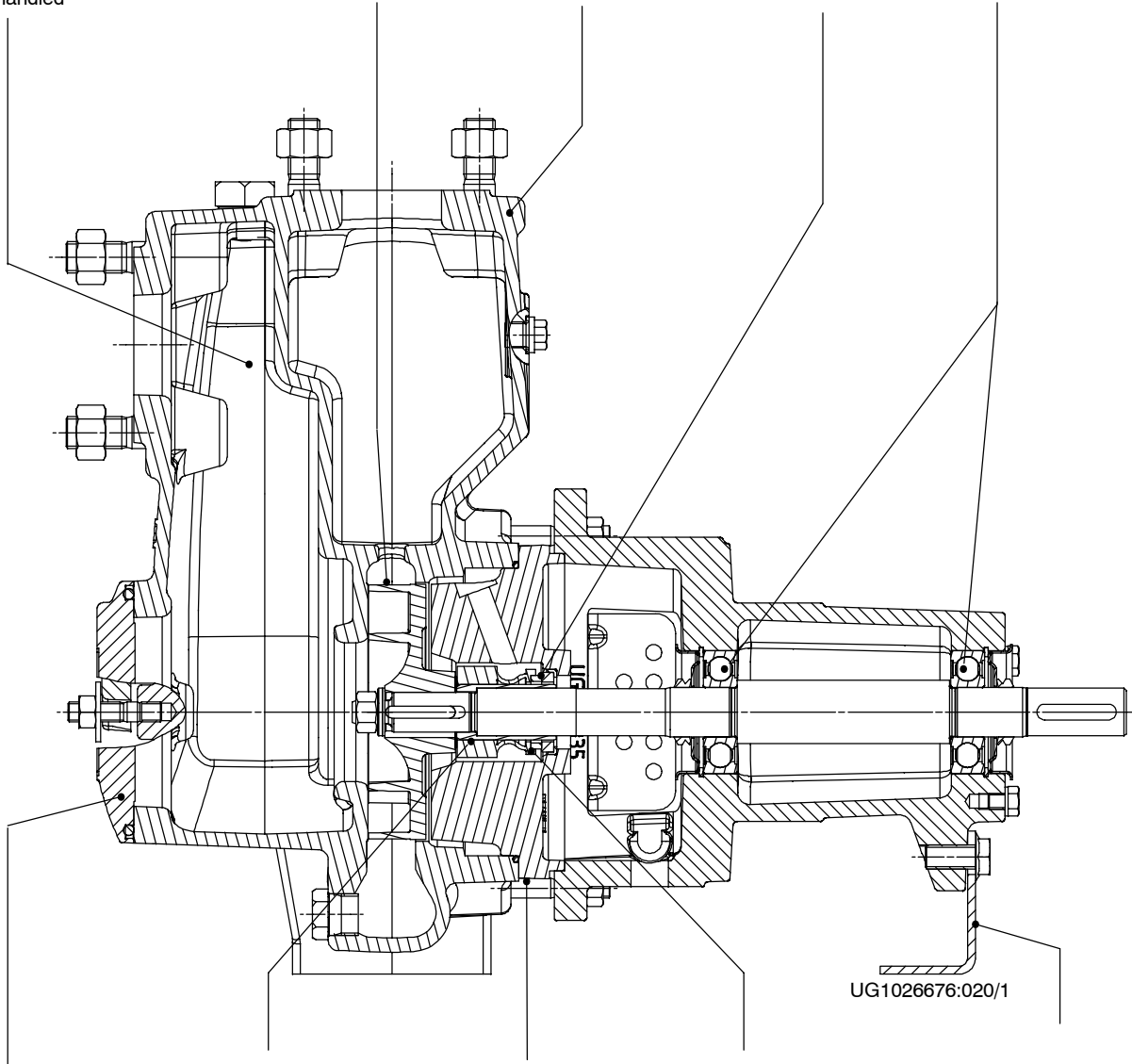

UG1026676:020/1

Inspection cover for easy cleaning

Shaft sleeve prevents wear on the shaft

Back pull-out design: the casing may remain in the pipeline when the pump is dismantled

Reliable, maintenance-free mechanical seal

Sturdy support foot: even in the case of external forces the shaft is only slightly displaced in the coupling area

Overview of Type Series

sizes and types available

Pump size	Shaft unit	ETAPRIME L		ETAPRIME BN		ETAPRIME B	
		GL JL 1040	CL 1.4408	GBN JL 1040	CBN 1.4408	GB JL 1040	
25 - 100	17	E/T	o	E/T	o	o	o
32 - 120		E/T	E/T	E/T	E/T	o	o
40 - 110		E/T	E/T	E/T	E/T	o	o
40 - 140	25	E/T/B	E/T/B	E/T/B	E/T/B	E	o
50 - 130		E/T/B	E/T/B	E/T/B	E/T/B	E	o
50 - 160		E/T/B	E/T/B	E/T/B	E/T/B	E	o
65 - 150		E/T/B	E/T/B	E/T/B	E/T/B	E	o
65 - 180	35	E/T/B	E/T/B	E/T/B	E/T/B	o	o
80 - 170		E/T/B	E/T/B	E/T/B	E/T/B	o	o
80 - 190		E/T/B	o	E/T/B	o	o	o
80 - 200		E/T/B	E/T/B	E/T/B	E/T/B	o	o
100 - 240.1		E/T/B	o	E/T/B	o	o	o
100 - 240		E/T/B	o	o	o	o	o
125 - 260	E/T/B	o	o	o	o	o	

- = available size
 o = size not available
 E = single-acting mechanical seal (standard design)
 T = double-acting mechanical seal in TANDEM arrangement possible
 B = double-acting mechanical seal in BACK-to-BACK arrangement possible

Materials

Designation	Etaprime GL		Etaprime CL	
Volute casing	Cast iron	JL 1040 ⁵⁾	Cast chrome nickel molybdenum steel	1.4408
Casing cover	Cast iron	JL 1040 ⁵⁾	Cast chrome nickel molybdenum steel	1.4408
Shaft	Tempering steel	C 45+N ⁴⁾	Chrome nickel molybdenum steel	1.4462 ⁴⁾
Impeller	Cast iron	JL 1040 ⁵⁾	Cast chrome nickel molybdenum steel	1.4408
Bearing bracket ²⁾	Cast iron	JL 1040 ⁵⁾	Cast iron	JL 1040 ⁵⁾
Bearing housing ³⁾	Cast iron	JL 1040 ⁵⁾	Cast chrome nickel molybdenum steel	1.4408
Shaft sleeve ¹⁾	Chrome nickel molybdenum steel	1.4571	Chrome nickel molybdenum steel	1.4571

- 1) omitted on shaft unit 17
 2) for shaft unit 25 and shaft unit 35
 3) for shaft unit 17
 4) for shaft unit 17 = Chrome nickel molybdenum steel 1.4571
 5) GJL-250 to EN 1561

For shaft unit / pump size combinations see Overview of Type Series above

Flange Connections / Pump connections

Pump size	Shaft unit	Standard connection	Special connection
25 - 100	17	Pipe thread	Pipe thread
32 - 120		Rp to ISO 7/1	NPT to ASME B1.20.1
40 - 110			
40 - 140	25	Flange to EN 1092-2, PN16, (JL 1040) to EN 1092-1, PN16, (1.4408)	Flange to ASME BE 16.1 Class 125 (to ZN 2606)
50 - 130			
50 - 160			
65 - 150			
65 - 180	35	Flange to EN 1092-2, PN16, (JL 1040) to EN 1092-1, PN16, (1.4408)	Flange to ASME BE 16.1 Class 125 (to ZN 2606)
80 - 170			
80 - 190			
80 - 200			
100 - 240.1			
100 - 240			
125 - 260			

Pressure Limits

Pump size	Dis-charge pressure $p_2^{1)}$ (bar)	Test pressure $p_2^2)$ (bar)	Pump size	Dis-charge pressure $p_2^{1)}$ (bar)	Test pressure $p_2^2)$ (bar)
25-100	10.0	15.0	65-180	10.0	15.0
32-120	10.0	15.0	80-170	10.0	15.0
40-110	10.0	15.0	80-190	10.0	15.0
40-140	10.0	15.0	80-200	10.0	15.0
50-130	10.0	15.0	100-240.1	10.0	15.0
50-160	10.0	15.0	100-240	10.0	15.0
65-150	10.0	15.0	125-260	10.0	15.0

- 1) The sum of inlet pressure and head at zero flow point must not exceed the values indicated.
- 2) The casing components are checked for leakage by means of internal pressure tests to AN 1897/75-03 with water.

Priming Time

with a horizontal length of the suction line of 1 m and suction line $D_N = \text{pump } D_N$

ETAPRIME L	Suction time [sec] for speed $n = 2,900/3,500$ rpm at a static suction lift $H_{1\text{geo}}$ of ... m				
	2 m	4 m	5 m	7 m	8 m
25-100	50	135	240	-	-
32-120	30	90	120	255	360
40-110	60	135	180	300	360
40-140	30	80	100	210	300
50-130	50	120	150	245	300
50-160	30	60	90	180	240
65-150	60	150	180	300	360
65-180	30	50	80	150	210
80-170	50	120	180	300	360
80-190	50	65	90	150	180
80-200	30	60	80	195	180
100-240.1	30	50	60	90	-
100-240	35	55	70	105	-
125-260	35	55	70	105	-

ETAPRIME L	Suction time [sec] for speed $n = 1,450/1,750$ rpm at a static suction lift $H_{1\text{geo}}$ of ... m					
	1 m	2 m	4 m	5 m	7 m	8 m
25-100	120	-	-	-	-	-
32-120	150	200	-	-	-	-
40-110	140	-	-	-	-	-
40-140	120	240	-	-	-	-
50-130	200	360	-	-	-	-
50-160	180	320	-	-	-	-
65-150	180	360	-	-	-	-
65-180	160	180	360	-	-	-
80-170	150	240	420	-	-	-
80-190	120	160	300	-	-	-
80-200	80	120	240	300	-	-
100-240.1	100	140	280	400	-	-
100-240	160	200	450	-	-	-
125-260	80	120	160	180	380	560

The above data refers to water at 20 °C.

Caution

When handling fluids which liberate gas or tend to froth, **the pump will not be self-priming.**

In such cases, a check valve should be installed in the suction line.

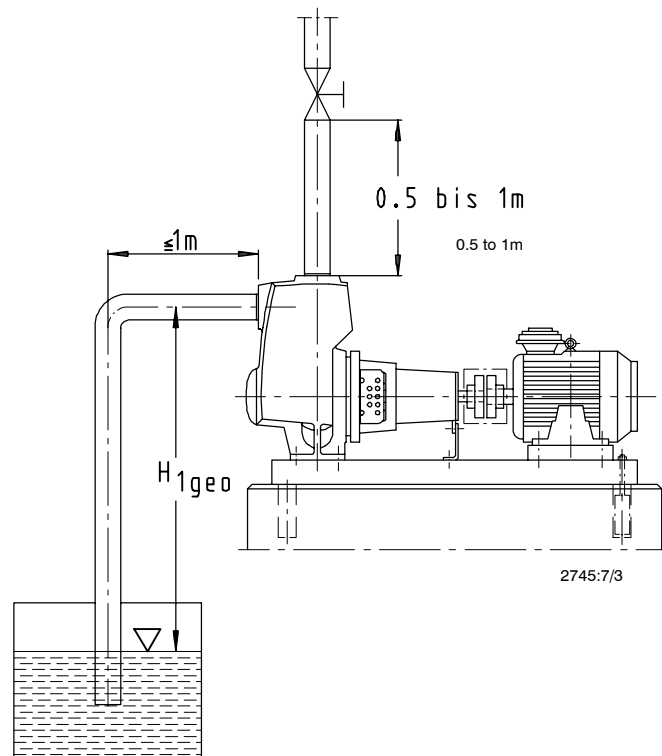

Fluid handled	Application limits	Materials		Shaft seal				Reference code	Comments
		Casing/Impeller		Mechanical seal					
		Cast iron/ Cast CrNiMo steel/ Cast CrNiMo steel/ Cast CrNiMo steel	Cast iron/ Cast CrNiMo steel/ Cast CrNiMo steel/ Cast CrNiMo steel	AQ1VGG 2)	U3U3VGG	Q1Q1X4GG	BQ1EGG 2)		
G	C	8	9	10	11				
Water									
Ammonia water (salmiac)	t ≤ 40 °C; conc. ≤ 10%	X					X	GL 11	
Brackish water	t ≤ 25 °C		X				X	CL10	
Condensate 2)	t ≤ 90 °C	X					X	GL11	
Condensate, non-conditioned	t ≤ 90 °C		X				X	CL11	
Cooling water 1) (no anti-freezes)	t ≤ 60 °C	X					X	GL10	open circuit: CL10 required
Cooling water pH value ≥ 7.5 (with anti-freeze 1)3)	t ≥ -30 °C p ≤ 10 bar t ≤ 90 °C	X					X	GL11	open circuit: CL11 required
Dam water 1)	t ≤ 60 °C	X					X	GL10	if containing solid matter - contact KSB
Drinking water 1)	t ≤ 60 °C	X					X	GL11	
Fire-fighting water 1)	t ≤ 60 °C	X					X	GL10	
Fully desalinated water	t ≤ 90 °C		X				X	CL11	Requirements for ultra-pure water cannot be met.
Fully desalinated water as boiler feed water 2)	t ≤ 90 °C	X					X	GL11	
Partly desalinated water 2)	t ≤ 90 °C	X					X	GL11	
Pure water 4)	t ≤ 60 °C	X					X	GL11	
Seawater	t ≤ 25 °C		X				X	CL10	
Slightly contaminated water 1)	t ≤ 60 °C	X					X	GL10	
Surface water 1)	t ≤ 40 °C	X		X				GL 8	Analysis of fluid handled required.
Swimming-pool water 1) (fresh water)	t ≤ 60 °C	X					X	GL10	Also for requirements to DIN 19 643
Untreated water 1)	t ≤ 60 °C	X					X	GL10	
Waste water (industrial)									Analysis of fluid handled required.
Refrigerants, cooling brines									
Cooling brine, inorganic, pH value > 7.5; inhibited	t ≥ -30 °C t ≤ 25 °C	X					X	GL11	
Water with anti-freeze, pH value ≥ 7.5 1)3)	t ≥ -30 °C; t ≤ 90 °C	X					X	GL11	
Oils/Emulsions									
Drilling/Grinding emulsion	t ≤ 60 °C	X					X	GL 9	
Oil-water emulsion	t ≤ 60 °C	X					X	GL 9	
Cleaning agents									
Bottle rinsing lyes	t ≤ 90 °C	X					X	GL10	
Acids									
Acetic acid	t ≤ 60 °C; conc. ≤ 5% t ≤ 60 °C; conc. ≤ 10%		X				X	CL 11	

- 1) General criteria for results of water analysis: pH value ≥ 7;
chloride (Cl) content ≤ 150 mg/kg. Chlorine (Cl₂) ≤ 0.6 mg/kg
Ammonia (NH₃) ≤ 5mg/kg, free from hydrogen sulphide (H₂S); no limitation of Cl content required in this case.
- 2) Treatment to VdTUV 1466; additional requirement: O₂ ≤ 0.02 mg/l
- 3) Antifreeze on ethylene glycol basis with inhibitors. Content: 20 % to 50 % (e.g. Antifrogen N)
- 4) No ultra-pure water! Conductivity at 25 °C: ≤ 800 µS/cm.

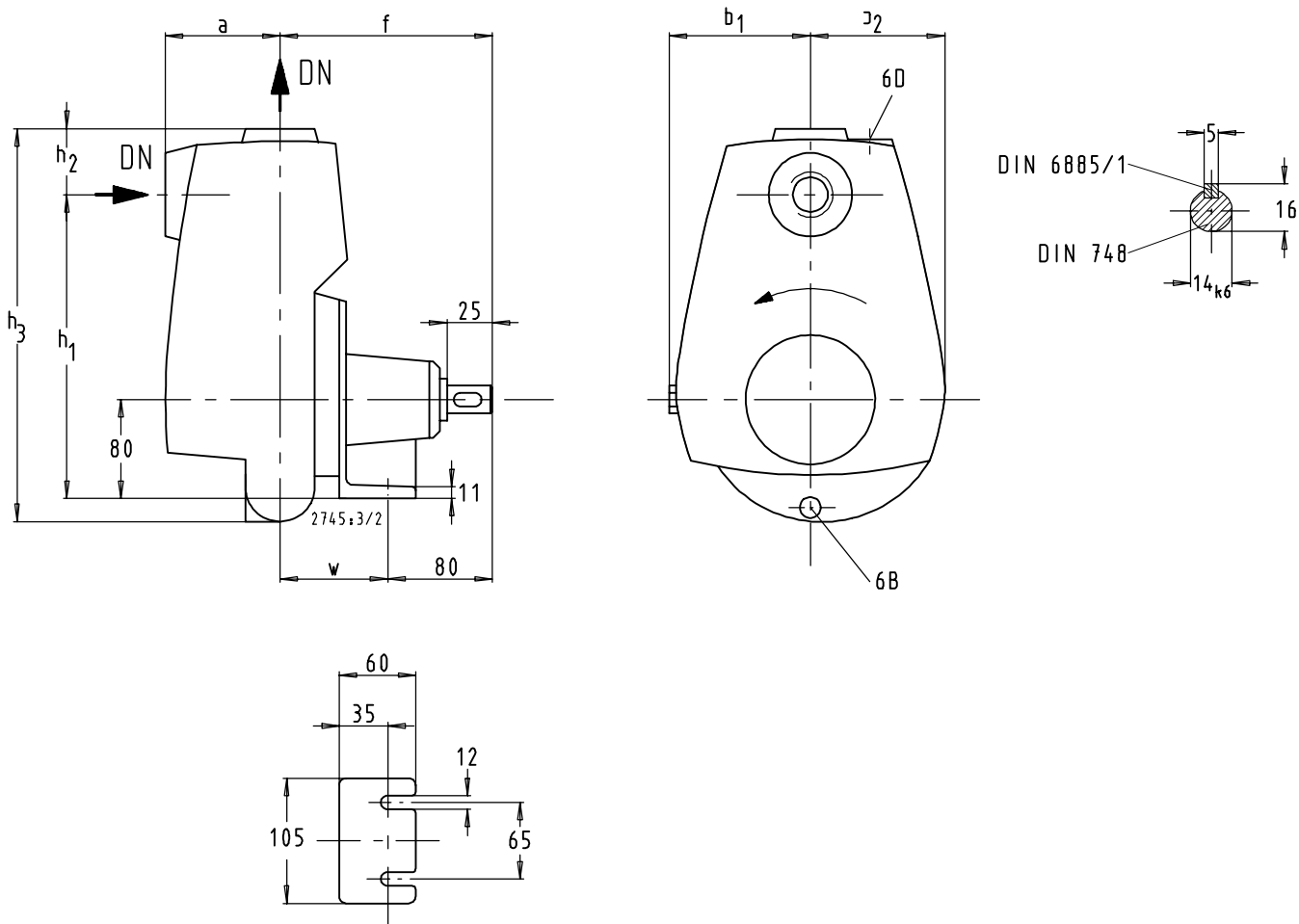
Etaprime L 25-100 - 40-110 (Shaft unit 17)

Etaprime L	6 B ¹⁾	6 D ¹⁾
25-100	R _c 1/8	R _c 3/4
32-120	R _c 1/8	R _c 3/4
40-110	R _c 1/8	R _c 3/4

6 B	Förderflüssigkeit-Entleerung / Casing drain / Vidange du liquide véhiculé / Scarico del liquido convogliato / Vaciado del líquido de impulsión / aftap. pomphuis
6 D	Förderflüssigkeit-Auffüllen und Entlüften / Fluid handled-priming and venting / Remplissage et dégazage de liquide véhiculé / Riempimento e scarico del liquido convogliato / Llenado y desaireación del líquido de impulsión / vul en ontluchting

1) R_c = ISO 7/1

mm

Etaprime L	Connection		a	b ₁	b ₂	f	h ₁	h ₂	h ₃	w
	Standard DN ²⁾	Special DN ³⁾								
25-100	Rp 1	NPT 1	70	104	95	169	220	38	265	89
32-120	Rp 1 1/4	NPT 1 1/4	95	118	95	165	229	46	286	85
40-110	Rp 1 1/2	NPT 1 1/2	105	118	110	171	235	55	312	91

2) Standard connection to ISO 7/1

3) Special connection to ASME B1.20.1

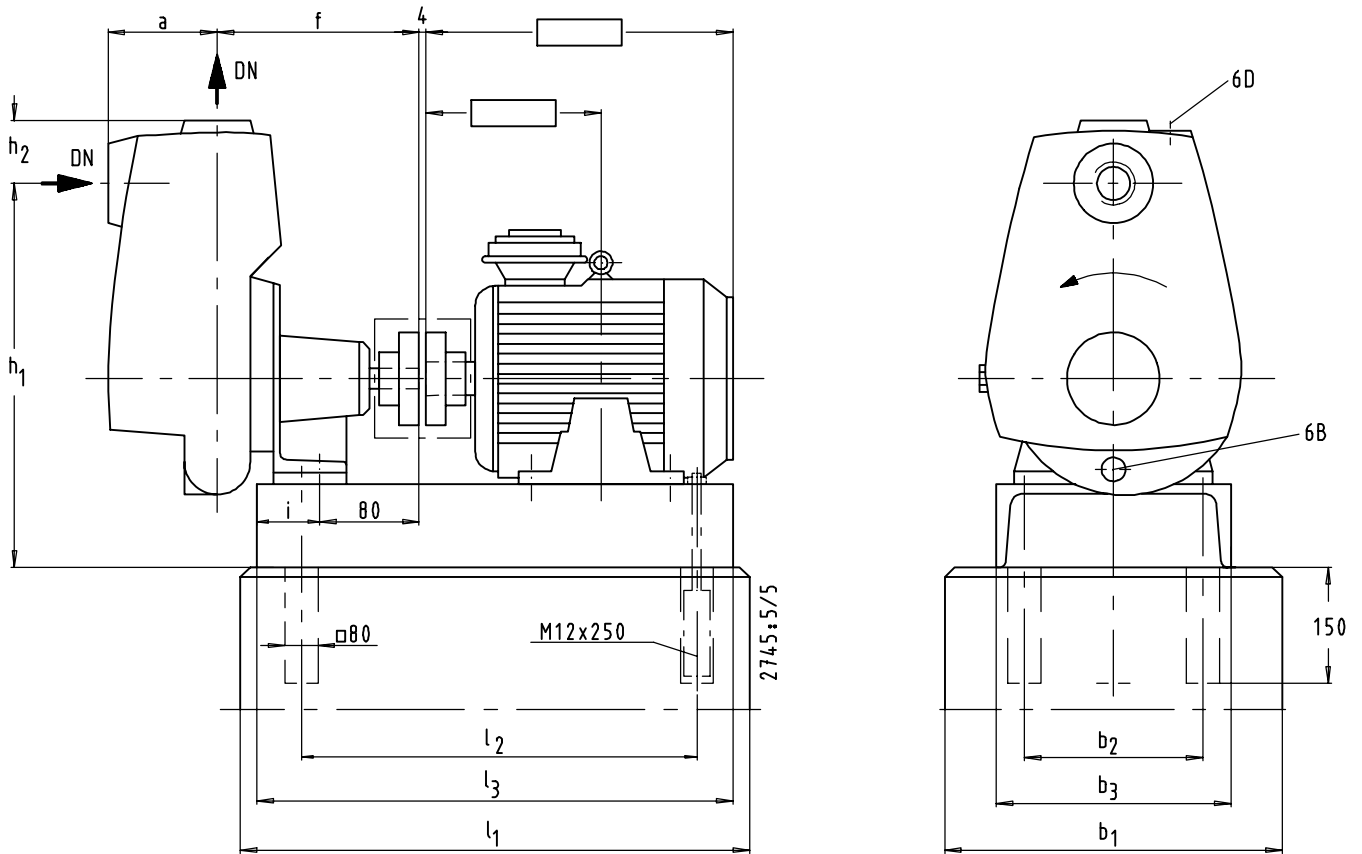
Etaprime L 25-100 - 40-110 (Shaft unit 17)

Tolerances of connecting dimensions as per EN 735

mm

Etaprime L	n = 1.450 1/min	n = 1.750 1/min	n = 2.900 1/min	n = 3.500 1/min	Motor		Connection		a	f	h ₁	h ₂	b ₁	b ₂	b ₃	i	l ₁	l ₂	l ₃
					kW	IEC	Standard DN ²⁾	Special DN ³⁾											
25-100	X	X			0.37	71	Rp 1	Rp 1	70	169	295	38	350	160	200	41,5	570	360	400
25-100	X	X			0.55	80	Rp 1	Rp 1	70	169	295	38	350	160	200	41,5	570	360	400
25-100			X		0.55	71	Rp 1	Rp 1	70	169	295	38	350	160	200	41,5	570	360	400
25-100				X	0.75	80	Rp 1	Rp 1	70	169	295	38	350	160	200	41,5	570	360	400
25-100				X	1.1	80	Rp 1	Rp 1	70	169	295	38	350	160	200	41,5	570	360	400
32-120	X	X			0.37	71	Rp 1 1/4	NPT 1 1/4	95	165	304	46	350	160	200	41,5	570	360	400
32-120	X	X			0.55	80	Rp 1 1/4	NPT 1 1/4	95	165	304	46	350	160	200	41,5	570	360	400
32-120			X		1.1	80	Rp 1 1/4	NPT 1 1/4	95	165	304	46	350	160	200	41,5	570	360	400
32-120				X	2.2	90 L	Rp 1 1/4	NPT 1 1/4	95	165	304	46	350	160	200	41,5	570	360	400
40-110	X	X			0.37	71	Rp 1 1/2	NPT 1 1/2	105	171	310	55	350	160	200	41,5	570	360	400
40-110	X	X			0.55	80	Rp 1 1/2	NPT 1 1/2	105	171	310	55	350	160	200	41,5	570	360	400
40-110			X		1.1	80	Rp 1 1/2	NPT 1 1/2	105	171	310	55	350	160	200	41,5	570	360	400
40-110				X	1.5	90 S	Rp 1 1/2	NPT 1 1/2	105	171	310	55	350	160	200	41,5	570	360	400

2) Standard connection to ISO 7/1

3) Special connection to ASME B1.20.1

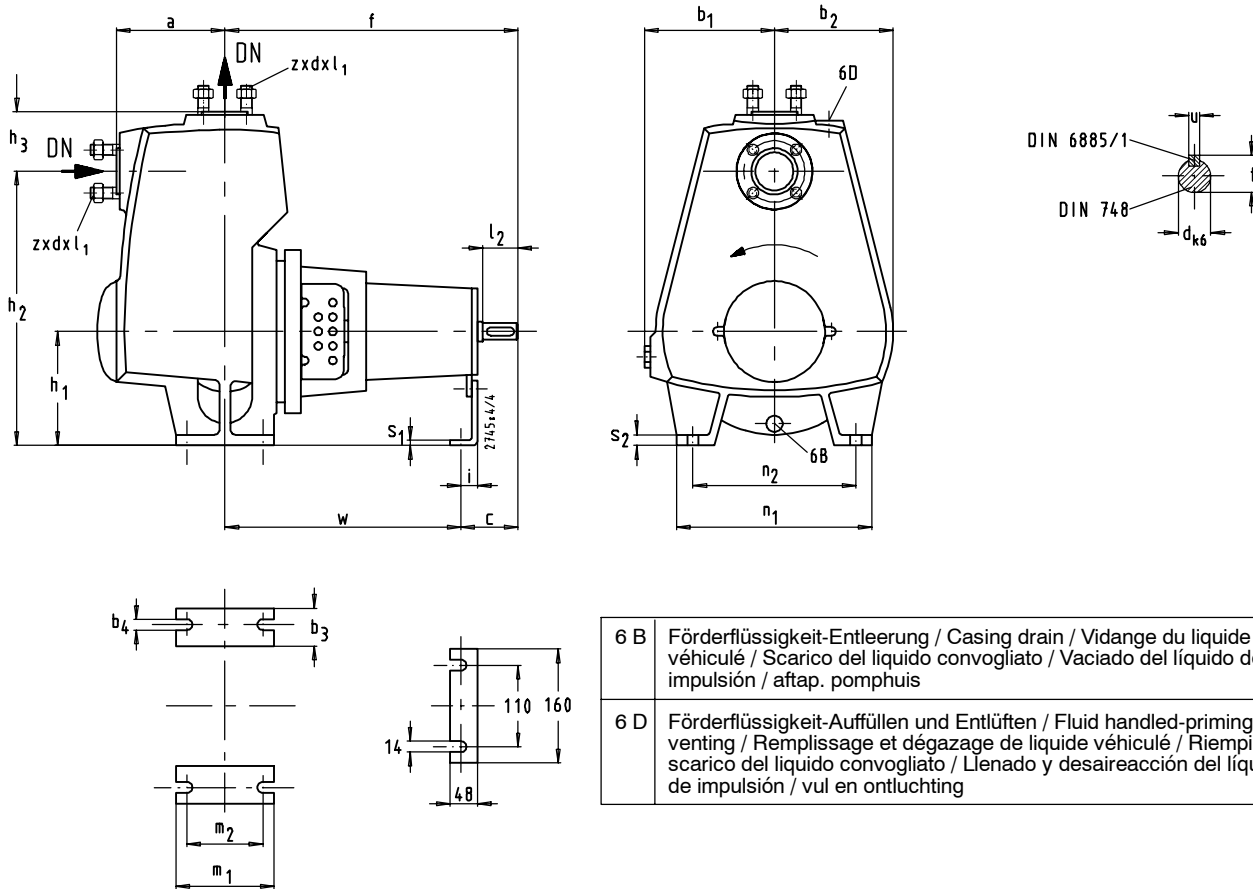
Etaprime L 40-140 - 125-260 (Shaft units 25 and 35)

6 B	Förderflüssigkeit-Entleerung / Casing drain / Vidange du liquide véhiculé / Scarico del liquido convogliato / Vaciado del líquido de impulsión / aftap. pomphuis
6 D	Förderflüssigkeit-Auffüllen und Entlüften / Fluid handled-priming and venting / Remplissage et dégazage de liquide véhiculé / Riempimento e scarico del liquido convogliato / Llenado y desaireación del líquido de impulsión / vul en ontluchting

Etaprime L	6 B ¹⁾	6 D ¹⁾
40-140	Rc ³ / ₈	Rc ³ / ₄
50-130	Rc ¹ / ₂	Rc ³ / ₄
50-160	Rc ¹ / ₂	Rc ³ / ₄
65-150	Rc ¹ / ₂	Rc ³ / ₄
65-180	Rc ¹ / ₂	Rc ³ / ₄
80-170	Rc ³ / ₄	Rc ³ / ₄
80-190	Rc ³ / ₈	Rc ³ / ₄
80-200	Rc ¹ / ₂	Rc ³ / ₄
100-240.1	Rc ³ / ₄	Rc ³ / ₄
100-240	Rc ³ / ₄	Rc ³ / ₄
125-260	Rc ³ / ₄	Rc ³ / ₄

1) Rc = ISO 7/1

Flange dimensions						mm	
Flange connection	DN	Dia. of bolt circle	z	d	l ₁		
Standard EN 1092-1 EN 1092-2	40	110	4	M 16	40		
	50	125					
	65	145	8		45		
	80	160					
	100	180					
Special ASME BE 16.1 Class 125 (ZN 2606)	125	210	4	UNC 1/2-13	40		
	40	98,6					
	50	120,7	8	UNC 5/8-11	45		
	65	139,7					
	80	152,4					
100	190,5	8	UNC 3/4-10	45			
125	215,9						

mm

Etaprime L	DN	a	b ₁	b ₂	b ₃	b ₄	c	d _{K6}	f	h ₁	h ₂	h ₃	i	l ₂	m ₁	m ₂	n ₁	n ₂	s ₁	s ₂	t	u	w
40-140	40	115	115	128	40	16	100	24	370	112	284	73	23	50	100	70	200	160	4	13	27	8	270
50-130	50	130	138	128	50	16	100	24	370	132	317	78	23	50	100	70	240	190	4	17	27	8	270
50-160	50	130	145	126	50	16	100	24	370	132	327	75	23	50	100	70	240	190	4	17	27	8	270
65-150	65	140	155	149	50	16	100	24	370	160	370	85	25	50	125	95	260	212	6	20	27	8	270
65-180	65	140	158	138	50	16	130	32	490	160	376	89	23	80	125	95	260	212	4	18	35	10	360
80-170	80	156	173	168	55	18	130	32	490	160	380	104	23	80	140	106	290	240	4	18	35	10	360
80-190	80	170	188	181	65	20	130	32	490	180	420	107	24	80	160	120	345	280	6	22	35	10	360
80-200	80	154	172	152	58	20	130	32	490	160	378	107	24	80	140	100	270	220	4	22	35	10	360
100-240.1	100	182	203	178	60	20	130	32	478	200	457	127	24	80	140	100	320	260	6	18	35	10	348
100-240	100	182	203	178	60	20	130	32	478	200	457	127	24	80	140	100	320	260	6	18	35	10	348
125-260	125	204	227	197	70	20	130	32	478	200	486	142	24	80	140	100	340	270	6	18	35	10	348

Etaprime L 40-140 - 125-260 (Shaft units 25 and 35)
with normal coupling

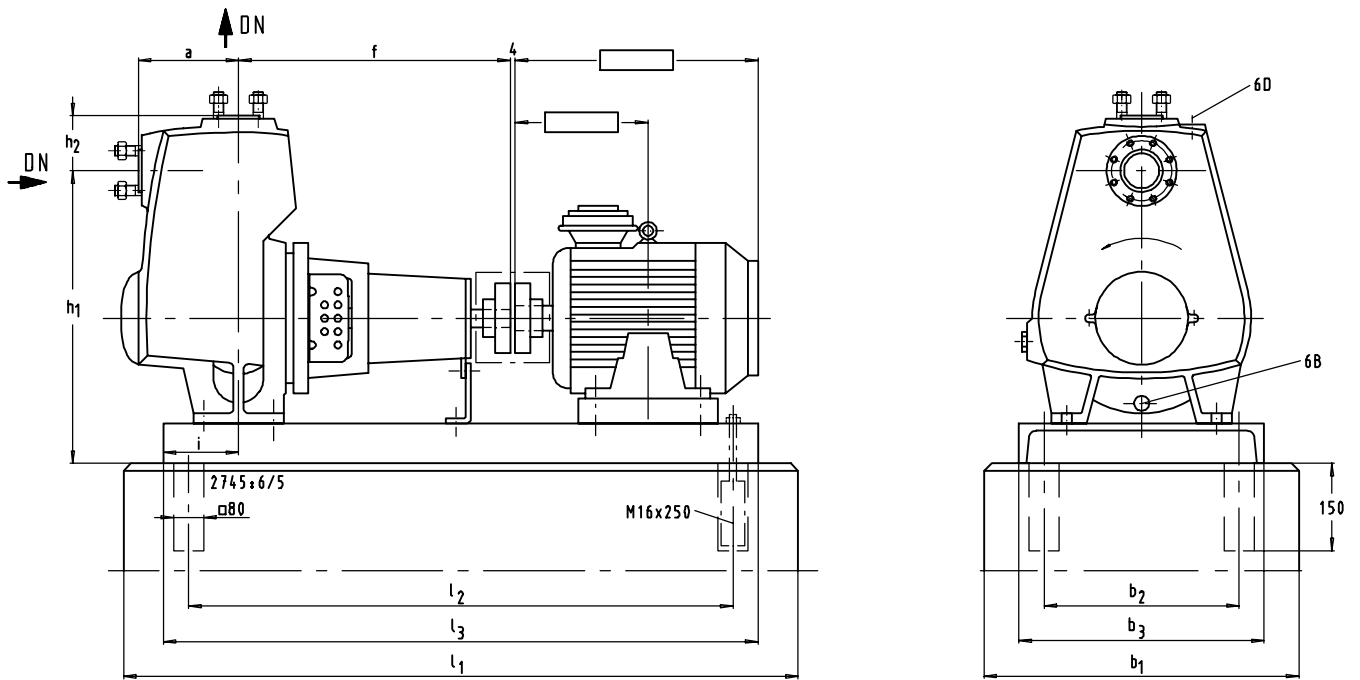

with normal coupling

Tolerances of connecting dimensions as per EN 735

mm

Etaprime L Pump size	n = 1.450 1/min	n = 1.750 1/min	n = 2.900 1/min	n = 3.500 1/min	Motor		DN	a	f	h ₁	h ₂	b ₁	b ₂	b ₃	i	l ₁	l ₂	l ₃ [mm]
					Power [kW]	Size												
40-140	X	X			1.5	90L	40	115	370	384	73	450	240	300	100	950	740	800
40-140			X		2.2	90L	40	115	370	384	73	450	240	300	100	950	740	800
40-140			X		3	100L	40	115	370	384	73	450	240	300	100	950	740	800
40-140				X	4	112M	40	115	370	384	73	450	240	300	100	1050	840	900
40-140				X	5.5	132S	40	115	370	404	73	450	240	300	100	1050	840	900
50-130	X	X			1.5	90L	50	130	370	417	78	450	240	300	100	950	740	800
50-130			X		2.2	90L	50	130	370	417	78	450	240	300	100	950	740	800
50-130			X		3	100L	50	130	370	417	78	450	240	300	100	950	740	800
50-130				X	4	112M	50	130	370	417	78	450	240	300	100	1050	840	900
50-160	X	X			1.5	90L	50	130	370	427	75	450	240	300	112	950	740	800
50-160			X		4	112M	50	130	370	427	75	450	240	300	112	1050	840	900
50-160			X	X	5.5	132S	50	130	370	427	75	450	240	300	112	1150	940	1000
50-160				X	7.5	132S	50	130	370	427	75	450	240	300	112	1150	940	1000
65-150	X	X			1.5	90L	65	140	370	470	85	450	240	300	112	950	740	800
65-150			X		4	112M	65	140	370	470	85	450	240	300	112	1050	840	900
65-150			X	X	5.5	132S	65	140	370	470	85	450	240	300	112	1150	940	1000
65-150				X	7.5	132S	65	140	370	470	85	450	240	300	112	1150	940	1000
65-180	X	X			2.2	100L	65	140	490	476	89	500	280	350	112	1270	1060	1120
65-180			X		5.5	132S	65	140	490	476	89	500	280	350	112	1270	1060	1120
65-180			X		7.5	132S	65	140	490	476	89	500	280	350	112	1270	1060	1120
65-180				X	11	160M	65	140	490	476	89	500	280	350	112	1270	1060	1120
80-170	X	X			2.2	100L	80	156	490	480	104	500	280	350	120	1270	1060	1120
80-170			X		7.5	132S	80	156	490	480	104	500	280	350	120	1270	1060	1120
80-170				X	11	160M	80	156	490	480	104	500	280	350	120	1270	1060	1120
80-170				X	15	160M	80	156	490	480	104	500	280	350	120	1270	1060	1120
80-190	X	X			2.2	100L	80	170	490	520	107	500	280	350	130	1270	1060	1120
80-190	X	X			3	100L	80	170	490	520	107	500	280	350	130	1270	1060	1120
80-190			X		11	160M	80	170	490	520	107	500	280	350	130	1400	1190	1250
80-190				X	15	160M	80	170	490	520	107	500	280	350	130	1400	1190	1250
80-190				X	18.5	160L	80	170	490	520	107	500	280	350	130	1400	1190	1250
80-200	X	X			2.2	100L	80	154	490	478	107	500	280	350	120	1270	1060	1120
80-200			X		11	160M	80	154	490	478	107	500	280	350	120	1400	1190	1250
80-200				X	15	160M	80	154	490	478	107	500	280	350	120	1400	1190	1250
80-200				X	18.5	160L	80	154	490	478	107	500	280	350	120	1400	1190	1250
100-240.1	X	X			2.2	100L	100	182	478	557	127	500	280	350	120	1270	1060	1120
100-240.1	X	X			3	100L	100	182	478	557	127	500	280	350	120	1270	1060	1120
100-240.1	X	X			4	112M	100	182	478	567	127	500	280	350	120	1270	1060	1120
100-240.1			X		15	160M	100	182	478	557	127	500	280	350	120	1270	1060	1120
100-240.1				X	18.5	160L	100	182	478	557	127	500	280	350	120	1400	1190	1250
100-240.1				X	22	180M	100	182	478	567	127	550	320	400	120	1400	1190	1250
100-240.1				X	30	200L	100	182	478	567	127	550	320	400	120	1400	1190	1250
100-240	X	X			3	100L	100	182	478	567	127	500	280	350	120	1270	1060	1120
100-240	X	X			4	112M	100	182	478	567	127	500	280	350	120	1270	1060	1120
100-240	X	X			5.5	132S	100	182	478	567	127	500	280	350	120	1270	1060	1120
100-240			X		22	180M	100	182	478	567	127	550	320	400	120	1400	1190	1250
100-240				X	30	200L	100	182	478	567	127	550	320	400	120	1400	1190	1250
100-240				X	37	200L	100	182	478	567	127	550	320	400	120	1400	1190	1250
125-260	X	X			5.5	132S	125	204	478	596	142	500	280	350	120	1270	1060	1120
125-260	X	X			7.5	132M	125	204	478	596	142	500	280	350	120	1270	1060	1120
125-260	X	X			11	160M	125	204	478	596	142	550	320	400	120	1400	1190	1250
125-260			X		30	200L	125	204	478	596	142	550	320	400	120	1400	1190	1250
125-260				X	37	200L	125	204	478	596	142	550	320	400	120	1400	1190	1250

Etaprime L 40-140 - 125-260 (Shaft units 25 and 35)
with spacer-type coupling

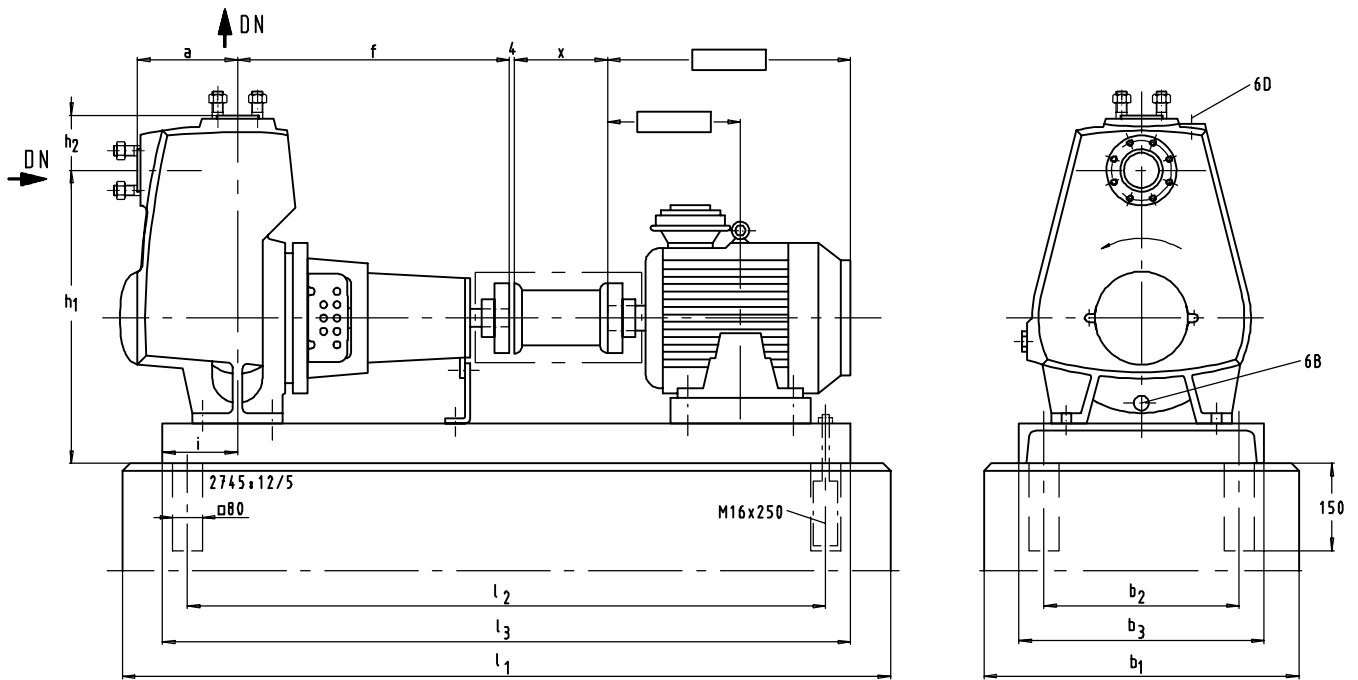

Interchangeability of Etaprime L and Etaprime B/BN Components and Interchangeability of Pump Parts

Etaprime	Shaft unit	Description								
		Volute casing	Casing cover	Shaft	Impeller	Deep-groove ball bearing	Deep-groove ball bearing	Bearing housing	Mechanical seal	Shaft sleeve
		Part No.	102	161	210	230	321.01	321.02	350	433.01
25-100	17	O	X	1	O	1	2	1	1	X
32-120	17	O	X	1	O	1	2	1	1	X
40-110	17	O	X	1	O	1	2	1	1	X
40-140	25	O	O	2	O	3	3	X	2	1
50-130	25	O	O	2	O	3	3	X	2	1
50-160	25	O	O	2	O	3	3	X	2	1
65-150	25	O	O	2	O	3	3	X	2	1
65-180	35	O	O	3	O	4	4	X	3	2
80-170	35	O	O	3	O	4	4	X	3	2
80-190	35	O	O	3	O	4	4	X	3	2
80-200	35	O	O	3	O	4	4	X	3	2
100-240.1	35	1	O	3	O	4	4	X	3	2
100-240	35	1	O	3	O	4	4	X	3	2
125-260	35	O	O	3	O	4	4	X	3	2

1) not available as Etaprime B/BN

1	same number means
1	same component
O	Components differ
X	Component not fitted
	Component interchangeable with Etaprime B/BN

Recommended Spare Parts Stock for 2 Years' Continuous Operation to DIN 24296

Part No.	Description	Number of Pumps (incl. stand-by pumps)							Quantity of spare parts
		2	3	4	5	6 and 7	8 and 9	10 and more	
210	Shaft	1	1	1	2	2	2	20 %	
230	Impeller	1	1	1	2	2	2	20 %	
321.01/02	Deep-groove ball bearing (Set)	1	1	2	2	2	3	25 %	
330	Bearing bracket	-	-	-	-	-	1	2 off	
350 1)	Bearing housing	-	-	-	-	-	1	2 off	
412.35/.65	O-ring (Set)	4	6	8	8	9	10	100 %	
433.01	Mechanical seal	1	1	2	2	2	3	25 %	
523 2)	Shaft sleeve	2	2	2	3	3	4	50 %	

1) for shaft unit 17 2)

2) Assigning shaft unit to pump size: see interchangeability of pump parts

Subject to technical modification without prior notice.

01.03.2005

2745.5/9-10

